

PROGRAMMABLE CONVERTER

TPI 10



Features

- **Power supply:**
20 to 270 Vac and 20 to 300 Vdc
- **Universal input:**
100mV, 1V, 10V, 300V,
20mA, Pt100 3 wire, Ni 100, thermo-
couple, resistance and potentiometer.
Typical response time: 300 ms
- Supply for 2-wire sensor
- **1 insulated analog output (A)**
programmable in 0-4-20mA current
(active/passive) or in 0-10V voltage.

Relay outputs (option R): 2 inverting relays
(8A/250 VAC on resistive load).

Detection of the sensor rupture.

*Insulation between input / outputs / supply.
Self-zero and self-diagnosis.*

*Mode driver : the analog output is
piloted by the micro-console.
Function simulation of the input measure.*

*Programming either with the micro-console
or by PC with the software SUPERVISION.*

Configuration

Easy programming on front face with a micro-console or with the PC software SUPERVISION.

Programming with the Micro-console

This minaturised micro-console connected on the front face of the instruments allows:

- the visualisation of the measure and the status of the analog and relay outputs,
- the visualisation and the modification of the programming,
- the teleloading of programming files for duplication to other converters.

Programming by PC: SUPERVISION

Programming software (Windows environment) allowing:

- the storage of configurations as files which can be consulted, modified, duplicated or loaded into the converters,
- the edition and printing of files with or without having a converter connected.

Dimensions

Self-extinguishing case of black UL 94VO ABS.

Mounting in switchbox: latching on symmetrical DIN rail.

Rack version: consult.

Plug-off connectors for screwed connectings
(2.5mm², flexible or rigid)

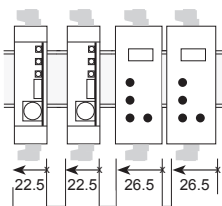

Dimensions: 22.5x75x120 mm
avec μ console: 26.5x80x130 mm

To allow the inserting of the μ console: mount the instruments vertically (horizontal DIN rail) leaving a 5mm space between each.

Operating T°: -10° to 50°C
Storage T°: -20 to 70°C

- ◆ **CE** according to IEC 61000-6-4, IEC 61000-6-2 (industrial environment).
- ◆ Disturbance immunity according to the standard IEC 61000-6-2 (IEC 61000-4-3 level 3, IEC 61000-4-4 level 4, IEC 61000-4-6 level 3)

Dimensions

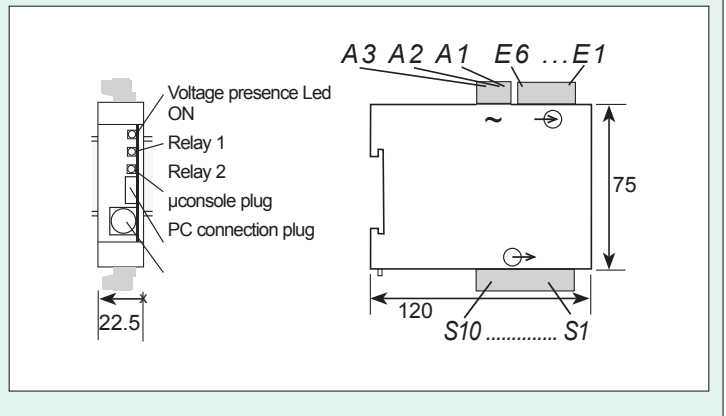

Coding

Type	TPI 10 AR
	<p>Outputs: A 1/U analog insulated R 2 inverting relays</p>

Power supply:

20 to 270 VAC and 20 to 300 Vdc

Power draw : 3.5 W max. 6 VA max.
Dielectric withstanding : 2 kV-50Hz-1min.

Order example: For a universal input converter + analog output + 2 relays, request reference TPI 10 AR.

Features

Inputs

Types of inputs	Measure range adjustable from:	Permanent overload	Intrinsic error	Console resolution	Input impedance
mA	-2 to +22mA ♣	± 100mA	< ±0.1% of the MR	10 µA	Max. drop 0.9V
mV♣	-10 to +110mV ♣	± 1V		10 µV	
V	-0.1 to +1.1V ♣	± 50V		1 mV	≥ 1MΩ
	-1 to +11V ♣			1 mV	
	-30 to +330V ♣	± 600V		10mV	
Thermocouples ♣ Standard IEC 581	°C	°F	< ±0.1% of the MR ♣(2)	0.1°C / 0.1°F	≥ 1 MΩ
J	-160/1200	-256/2192			
K	-270/1370	-454/2498			
B	200/1820	392/3308			
R	-50/1770	-58/3218			
S	-50/1770	-58/3218			
T	-270/410	-454/770			
E	-120/1000	-184/1832			
N	0/1300	-32/2372			
L	-150/910	-238/1670			
W	1000/2300	1832/4172			
W3	0/2480	32/4496			
WRE5	0/2300	32/4172			
Sensor Pt100Ω (1)♣ 3 wire, Stand. IEC 751 (DIN 43760)	°C	°F			
	-200/850	-328/1562			
Sensor Ni 100 3 wire (1)♣	-60/260	-76/500			
Resistive sensors	Calibers 0-440 Ω and 0-2.2 kΩ ♣ (0-8.8 kΩ optional)	-	< ±0.1% of the MR (0.5% for 0-2KΩ)	-	-
Potentiometer	from 100Ω to 10 kΩ ♣	-			
Supply for 2-wire sensor	24 Vdc ±15% with protection from short-circuits. 25 mA max.				
Special linearisation programming up to 20 points	On input: mV, V, mA. Resistive sensors and potentiometer				

- (1) Line resistance <25Ω
(2) Or 30 µV typical (60µV Max.)
♣ CJC efficiency : ±0.03°C/°C ±0.5°C from -5°C to +55°C
MR Measure range

♣ A 12 µA pulsed current allows the detection of line or sensor rupture
♣ Cut off: the display of the console and the output of the TPI remain at down scale for an input signal < to the cut off value, programmable from 0% to 100% of the input range.
Thermic drift <150ppm /°C

Outputs

Code	Types of OUTPUTS	Features
A	1 analog Active/passive current voltage	Current: Direct or reverse 0-20mA Load impedance ≤ Lr 600Ω Voltage: Direct or reverse 0-10V Load impedance ≥ Rc 5000Ω
R	2 inverting relays	2 setpoints per relay, configurable on the whole MR. Hysteresis programmable from 0 to 100%. Time delay programmable from 0 to 25 sec. (8A/250VAC on resistive load)

Typical response time: 300 ms (for a variation from 0 to 90 % of the input signal)

(1) Add 40 ms for the response time on the analog output.

Galvanic partition:

2kV-50Hz-1min. between supply, input, analog output, relay outputs

Connectings

Upper connectors

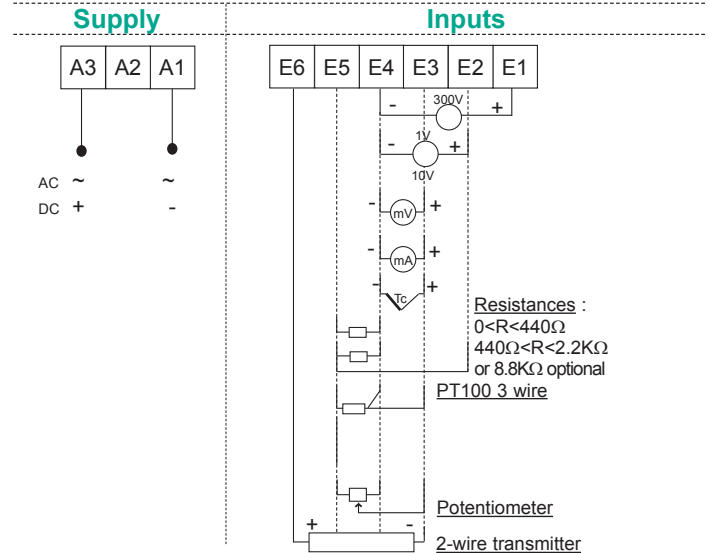

Lower connector

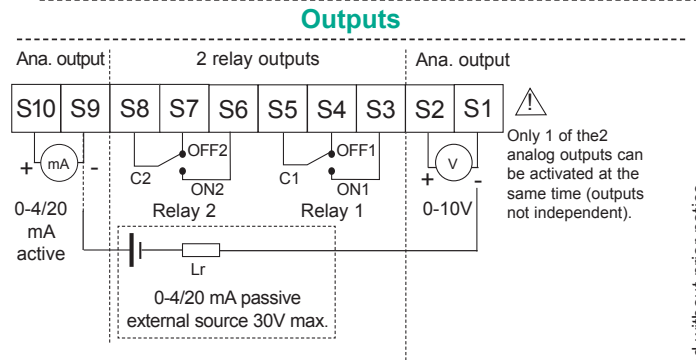

ARDETEM - CA CO/59 -H 05/08 - Any data in this documentation may be modified without prior notice.



RCS Lyon 444-429-476 - Printed in France.

e-mail : info@ardetem.com
http : //www.ardetem.com

Route de Brindas
Parc d'activité d'Arbora N°2
69510 SOUCIEU EN JARREST
- FRANCE -

Tél. : 33 (0)4 72 31 31 30
Fax. : 33 (0)4 72 31 31 31

your representative

