

PROGRAMMABLE DIGITAL BARGRAPHS

analog display of 64 segments on 92mm
digital display of 4 eight mm high digits

DIP-BAR

The DIP-BAR 1 and DIP-BAR 2 series indicators allow visualising the measure on 2 types of simultaneous displays:

- ▶ Analog: programmable bargraph (92 mm column made up of 64 red segments), display of the alarm setpoints, the overrange and the sensor rupture, position of the 0 programmable...
- ▶ Digital (4 eight mm high red digits)

DIP-BAR 1: 1 programmable measure channel
DIP-BAR 2: 2 programmable measure channels (not insulated from each other)

Universal programmable inputs:

Process inputs

(DC bidirectionnal current or voltage).

Temperature inputs (thermocouple or sensor).

Potentiometer and resistance inputs.

Universal power supply: 20 to 270 Vac & 20 to 300 Vdc



COMBINABLE OPTIONS: (specify on order).

Insulated analog outputs:

(and insulated from each other)

Active or passive current output, or voltage output.

Programmable scale ratio with enlarging effect.

Return value in case of sensor rupture and/or self-diagnosis error.

Relay outputs:

2 or 4 relays: mode setpoint or window.

Recording of the alarms.

Time delay and hysteresis adjustable on each setpoint.

Alarm messages.

Each analog or relay output can be assigned to either one of the 2 channels.

Introduction

The series DIP-BAR 1 and DIP-BAR 2 offer a complete range of highly accurate programmable bargraphs. The front display allows a simple and quick visualisation of the measure status. They allow the display, the control and the transmission of data from any measurable magnitudes.

Programming:

- from the keyboard of 3 keys accessible on front face
- via the configuration software SUPERVISION

Bargraph measure:

- Measure and value to be entered: (4 digits) -1999 to 9999.
- The bargraph top, bottom and zero are programmable in display value.

Display:

- Of the zero position, (the column is reversed around the zero).
- Of the overrange on the bargraph (10%), (shown by a blinking of the column).
- Of the position of the alarm setpoints, (shown by a segment of the column).
- Of the start up of the alarm, (shown by the blinking of a segment).
- The brightness of the bargraph and the digits can be programmed separately.

Dimensions

DIP-BAR 1 1 channel
DIP-BAR 2 2 channels

External dimensions of the case

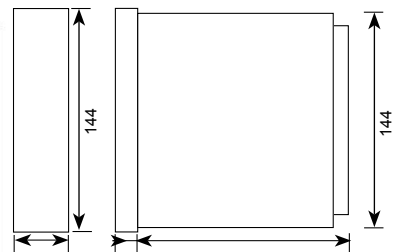
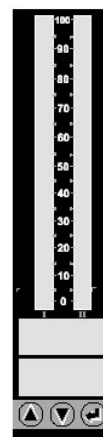

Housing: 144 x 36 x 137 mm (with terminals)

Mounting: on panel; cut out 33 x 138 mm

Tightening by screwed straps

Technical features

TYPES OF OUTPUT OPTIONS

option A	<p>2 analog outputs programmable in voltage or in current</p> <p>Active current output 0/4-20mA Passive current output 0/4-20mA (Vmax. = 30Vdc) Voltage output 0-10V</p> <ul style="list-style-type: none"> • Accuracy: 0.1 % in relation to the display (at +25°C). • Residual ripple ≤ 0.2%. • Admissible load $0\Omega < Lr < 600\Omega$ (current) $Lr > 5\text{ k}\Omega$ (voltage) • Programmable scale ratio with enlarging effect. • Response time: 40 ms. (to be added to the measure response time). 	option R4 or R	<p>Relay output: 2 types on choice</p> <p>R : 2 independently programmable setpoint relays R4 : 4 independently programmable setpoint relays</p> <ul style="list-style-type: none"> • Hysteresis independently programmable from 0 to 100% of the setpoint in the display. • Time delay independently programmable from 0 to 25 s. in 0.1s. increases • NO-NC contact 8 A - 250 V on resistive load.
-----------------	--	-----------------------	---

TYPES OF INPUTS: (1 OR 2 CHANNELS)

Current or voltage	<p>DC current or voltage</p> <p>Bidirectionnal ±100mV, ±1V, ±10V, ±300V, ±20mA.</p> <ul style="list-style-type: none"> • Accuracy: 0.1 % of the full scale at +25 °C. • Thermic drift < 150 ppm/°C. • Scale overstepping measurable from -10% to +10% • Programmable scale factor. • Enlarging effect - Square root extraction. • Special linearisation on 20 points. • Supply for 2 or 3-wire sensor 24 Vdc (±15%) -25 mA protected from short-circuits (max. nonlinearity 0.2% of the MR in 3-wire sensor) 	Temperature	<p>Temperature</p> <p>Thermocouples :</p> <table border="0"> <tr> <td>Type J</td> <td>min. -160 °C</td> <td>max. +1200 °C</td> </tr> <tr> <td>Type K</td> <td>min. -270 °C</td> <td>max. +1370 °C</td> </tr> <tr> <td>Type N</td> <td>min. +0 °C</td> <td>max. +1300 °C</td> </tr> <tr> <td>Type S</td> <td>min. -50 °C</td> <td>max. +1770 °C</td> </tr> <tr> <td>Type B</td> <td>min. +200 °C</td> <td>max. +1820 °C</td> </tr> <tr> <td>Type W5</td> <td>min. +0 °C</td> <td>max. +2300 °C</td> </tr> <tr> <td>Type T</td> <td>min. -270 °C</td> <td>max. +410 °C</td> </tr> <tr> <td>Type R</td> <td>min. -50 °C</td> <td>max. +1770 °C</td> </tr> <tr> <td>Type E</td> <td>min. -120 °C</td> <td>max. +1000 °C</td> </tr> <tr> <td>Type W</td> <td>min. 1000 °C</td> <td>max. +2300 °C</td> </tr> <tr> <td>Type W3</td> <td>min. 0 °C</td> <td>max. +2480 °C</td> </tr> <tr> <td>Type L</td> <td>min. -150 °C</td> <td>max. +910 °C</td> </tr> </table> <ul style="list-style-type: none"> • Accuracy: 0.1% of the full scale at +25°C, or 30µV typical (60µV max.). • Thermic drift < 150ppm/°C (except CJC) CJC efficiency: < 0.03°C/°C ± 0.5°C from -5°C to +55°C. <p>Sensors:</p> <table border="0"> <tr> <td>Pt 100Ω</td> <td>min -200 °C</td> <td>max. +850 °C</td> </tr> <tr> <td>Ni 100Ω</td> <td>min -60 °C</td> <td>max. +260 °C</td> </tr> </table> <ul style="list-style-type: none"> • Influence of the line resistance in 3-wire measure included in the class for 0<RI<25Ω. • Δ Pt100 2 wire measure from -200°C to +270°C (0<RI<10Ω) (max. resistance 400Ω). • Max. measure current: 250 µA. • Accuracy: 0.1% of the full scale at +25°C. • Thermic drift < 150ppm/°C. 	Type J	min. -160 °C	max. +1200 °C	Type K	min. -270 °C	max. +1370 °C	Type N	min. +0 °C	max. +1300 °C	Type S	min. -50 °C	max. +1770 °C	Type B	min. +200 °C	max. +1820 °C	Type W5	min. +0 °C	max. +2300 °C	Type T	min. -270 °C	max. +410 °C	Type R	min. -50 °C	max. +1770 °C	Type E	min. -120 °C	max. +1000 °C	Type W	min. 1000 °C	max. +2300 °C	Type W3	min. 0 °C	max. +2480 °C	Type L	min. -150 °C	max. +910 °C	Pt 100Ω	min -200 °C	max. +850 °C	Ni 100Ω	min -60 °C	max. +260 °C
Type J	min. -160 °C	max. +1200 °C																																											
Type K	min. -270 °C	max. +1370 °C																																											
Type N	min. +0 °C	max. +1300 °C																																											
Type S	min. -50 °C	max. +1770 °C																																											
Type B	min. +200 °C	max. +1820 °C																																											
Type W5	min. +0 °C	max. +2300 °C																																											
Type T	min. -270 °C	max. +410 °C																																											
Type R	min. -50 °C	max. +1770 °C																																											
Type E	min. -120 °C	max. +1000 °C																																											
Type W	min. 1000 °C	max. +2300 °C																																											
Type W3	min. 0 °C	max. +2480 °C																																											
Type L	min. -150 °C	max. +910 °C																																											
Pt 100Ω	min -200 °C	max. +850 °C																																											
Ni 100Ω	min -60 °C	max. +260 °C																																											
Potentiometer and resistance	<p>Potentiometer and resistance</p> <p>Resistive sensors: calibers 0-400 Ω and 0-2 kΩ (0-8 kΩ optional).</p> <ul style="list-style-type: none"> • Accuracy: 0.1% for the calibers 0-400 Ω and 0-8 kΩ and 0.5% for the caliber 0-2 kΩ (of the full scale at +25°C). • Thermic drift < 150ppm/°C. <p>Potentiometers: from 100 Ω to 10 kΩ.</p> <ul style="list-style-type: none"> • Accuracy: 0.1% of the full scale at +25°C. • Thermic drift < 150ppm/°C. 																																												

Environment

- **Universal power supply:**
20 to 270 Vac 50/60/400Hz and 20 to 300 Vdc
Power draw: 6 W max. 10 VA max.
- Operating temperature: -5 to 55°C.
- Storage temperature: -30°C to +80°C.
- Relative dampness: 80% annual average.
- **Housing:** Moulded plastic case (for panel mounting).
Front dimensions: 36 x 144 mm
Weight : 335g.
- **Connectors** plug-off connectors on rear face for screwed connections (2.5mm², flexible or rigid).
- **Protection:** Front face: IP 50 Case/terminals: IP20
- **Standards:**
 marking (according to the directive 2004/108/CE)
Conform with the standards IEC 61000-6-4 on rejections and IEC 61000-6-2 on immunity (in industrial environment)
IEC 61000-4-2 level 3, IEC 61000-4-3 level 3,
IEC 61000-4-4 level 4, IEC 61000-4-6 level 3

<p>◆ Features</p> <ul style="list-style-type: none"> • Sampling time: 100ms per measure channel • Input impedance $\geq 1\text{ M}\Omega$ for the voltage inputs Max. drop 0.9V for the current input • Rejection rate: Common mode: 130 dB Serial mode: 40 dB 50/60 Hz • Zero drift compensation and self-calibration • Insulation: Input / Outputs / Power supply: 2.5 kV eff. 50Hz-1min Analog output 1 / analog output 2: 1.0 kV eff. 50Hz- 1min <p>◆ Programmable integration indice</p> <p>Allows stabilising the display in case of unsteady input.</p> <p>◆ Detection of the line or sensor rupture</p> <ul style="list-style-type: none"> • Can be detected on mV, TC, Pt 100, Ni 100, ΔPt100, resistance and current (4-20 mA) inputs. • Return value programmable on the analog output in case of sensor rupture. • Status of each of the 4 relays in case of sensor rupture programmable. • Possibility to disconnect the sensor rupture. <p>◆ Self-diagnosis:</p> <ul style="list-style-type: none"> • Permanently watches any drifts of the components. Serves to warn the user before they may provoke false measures. • Status of each of the 4 relays in case of self-diagnosis programmable. • Return value programmable on the analog output in case of self-diagnosis error. <p>◆ Input scale overrange</p> <p>Visualised on the display by a blinking measure.</p> <p>◆ Linearisations</p> <ul style="list-style-type: none"> • Linear input • Square root extraction (current or voltage inputs) • Special linearisation on 20 points (in X and in Y) (voltage or current or potentiometer or resistance inputs) <p>◆ Scale shifting (slope and offset)</p> <p>Programmable on all the inputs.</p> <p>◆ Brightness setting</p> <p>Independent setting of the digits and the leds/bargraphs brightness programmable: 4 levels, according to the location of the instrument (outdoor, control room...)</p> <p>◆ Quick reading on the digital display</p> <ul style="list-style-type: none"> • Of the value of the setpoints. • Of the input signal electrical value. • Of the min. and max. values <p>◆ Quick reading on the bargraph</p> <ul style="list-style-type: none"> • Of the level of the setpoints • Of the status of the relays. • Of the overrange or the sensor rupture. <p>◆ Function simulation</p> <ul style="list-style-type: none"> • Possibility to simulate the analog output (mode generator). • Possibility to simulate the measure: allows validating the configuration of the analog output and the relay outputs in the installation (mode simulation). 	<p>◆ Access code</p> <p>An access code adjustable from 0000 to 9999 serves to protect the meter and its setpoints from unauthorized programming and to lock the access to some functions. The factory code is 0000.</p> <table border="1"> <tr> <td>x x x x</td> <td>0 to 5 Access to the scale shifting</td> </tr> <tr> <td></td> <td>6 to 9 No access</td> </tr> <tr> <td>0 to 5</td> <td>Access to the measure and output simulations</td> </tr> <tr> <td>6 to 9</td> <td>No access</td> </tr> <tr> <td>0 to 5</td> <td>Access to the function "tare" (except t° inputs)</td> </tr> <tr> <td>6 to 9</td> <td>No access</td> </tr> <tr> <td>0 to 5</td> <td>Access to the quick entering of alarm setpt.</td> </tr> <tr> <td>6 to 9</td> <td>No access</td> </tr> </table> <p style="text-align: center;">Coding</p> <p>Input type DIP-BAR 1: 1 measure channel DIP-BAR 2: 2 measure channels</p> <p>Output options</p> <p>A : Analog (A1, A2, or A3: specify) 1 output if 1 measure channel, 2 outputs if 2 measure channels A1 = active current output A2 = passive current output A3 = voltage output</p> <p>R : 2 relays R4 : 4 relays</p> <p>Simultaneously combinable options</p> <p>A A / R A / R4 R4</p> <p>Order examples: For a bargraph with 1 input channel, 1 analog output and 2 relays request the reference: DIP-BAR1 A1R (if 4-20mA active current analog output) For a bargraph with 2 input channels, 2 analog outputs and 4 relays request the reference: DIP-BAR2 A1 R4 (if the analog outputs 1 and 2 are 4-20mA active current outputs)</p> <hr/> <p><i>This appliance is dedicated to industrial applications. It has to be installed in an electrical switchbox, or equivalent.</i></p>	x x x x	0 to 5 Access to the scale shifting		6 to 9 No access	0 to 5	Access to the measure and output simulations	6 to 9	No access	0 to 5	Access to the function "tare" (except t° inputs)	6 to 9	No access	0 to 5	Access to the quick entering of alarm setpt.	6 to 9	No access
x x x x	0 to 5 Access to the scale shifting																
	6 to 9 No access																
0 to 5	Access to the measure and output simulations																
6 to 9	No access																
0 to 5	Access to the function "tare" (except t° inputs)																
6 to 9	No access																
0 to 5	Access to the quick entering of alarm setpt.																
6 to 9	No access																

Wiring

INPUTS PROCESS

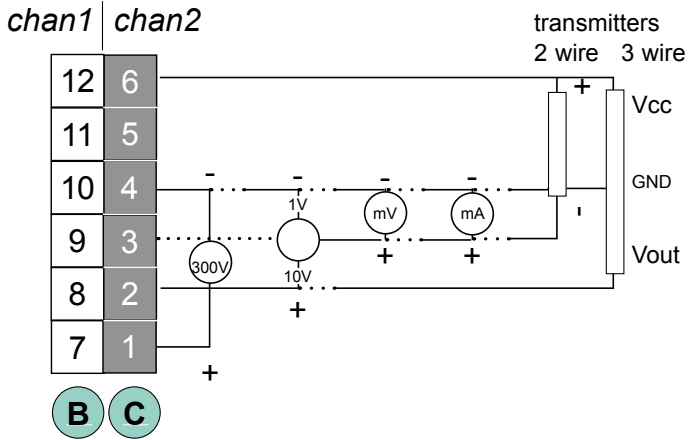

TEMPERATURE

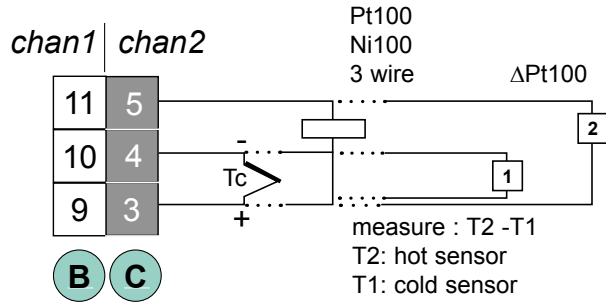

RESISTANCE AND POTENTIOMETER

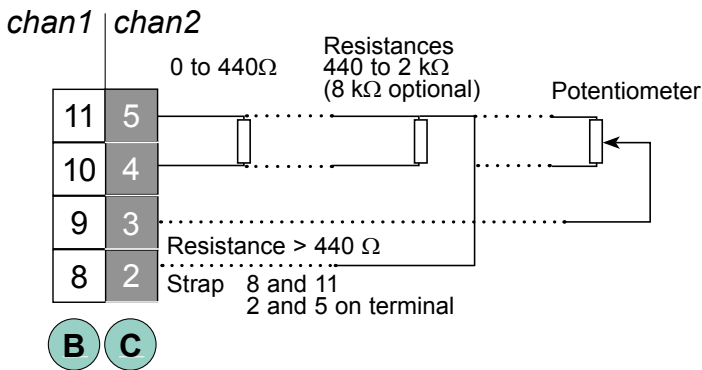

POWER SUPPLY

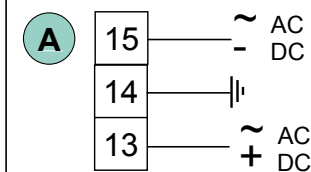

1 analog output

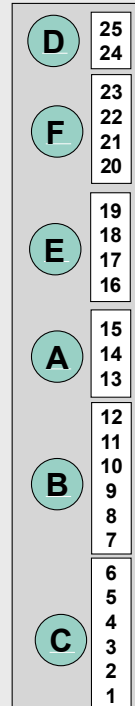

analog
output(s)

E+F =
output
4 relays

2 relays

Power supply

Input channel
1

Input channel
2

2 analog outputs

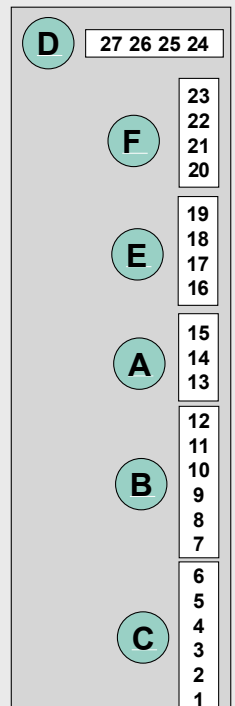

OUTPUTS (optional)

CURRENT OR VOLTAGE

2 outputs S1 and S2, insulated from each other

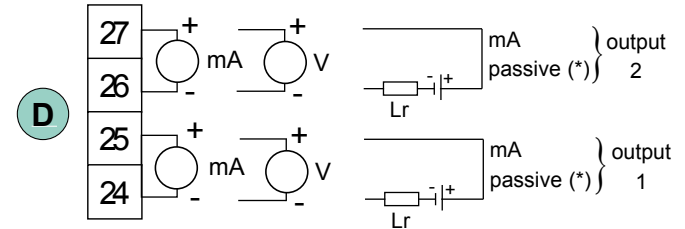

1 analog output

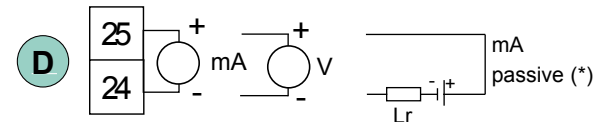

(*) 0 - 4 - 20 mA passive
external source 30V max.
type of output to be specified on order

2 OR 4 RELAYS

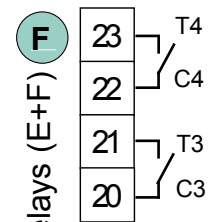
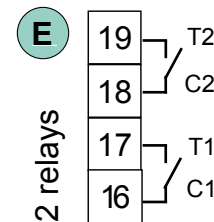

T: ON
C: Common

your representative



Route de Brindas
Parc d'activit  d'Arbora N 2
69510 SOUCIEU EN JARREST
FRANCE

e-mail : info@ardetem.com
http : //www.ardetem.com

T l. : 33 (0)4 72 31 31 30
Fax. : 33 (0)4 72 31 31 31