

Cable operated level indicator SFA

- Easy to install
- Convenient to viscous, aggressive, waste liquids
- Long or small tanks
- Adjustable level switches
- Kits for ordering

PRINCIPLE

The float, suspended to a cable supported with 2 pulleys, drives a balance weight inside the external transparent tube.
The balance weight has a built in magnet to operate the level switches.

DESCRIPTION

This SFA level indicator includes a float and a balance weight linked together by cable sliding on 2 pulleys.
The balance weight is guided inside a transparent PVC tube (Ø 63 x 57) and allows an easy level reading.
The guiding tube is fixed with PE collars; it is equipped in option with PVC graduated ruler, level switches.

CODE NUMBERS AND REFERENCES

583 010	SFA kit - Stainless steel model - (without PVC tube) including:	
	1 stainless steel AISI 316 float, Ø 200 mm	FI/200/SFA
	5 m stainless steel AISI 316 cable, Ø 1 mm	CIM/SFA
	2 stainless steel AISI 316 cable clips	SC/SFA
	1 pulley, tank mounting type	SFA/R
	1 pulley, tube mounting type	SFA/T
	1 balance weight with built in magnet	CP63/SFA
583 020	SFA kit - PPh model - (without PVC tube) including:	
	1 PPh float, Ø 98 mm	FP98/SFA
	5 m PPh cable, Ø 3 mm	CPM/SFA
	1 pulley, tank mounting type	SFA/R
	1 pulley, tube mounting type	SFA/T
	1 balance weight with built in magnet	CP63/SFA
583 030	SFA kit - PVC model - (without PVC tube) including:	
	1 PVC float, Ø 98 mm	FP/SFA/PVC
	5 m stainless steel cable PVC coated	CPM2/SFA
	1 pulley, tank mounting type	SFA/R
	1 pulley, tube mounting type	SFA/T
	1 balance weight with built in magnet	CP63/SFA
583 570	PVC transparent tube, Ø 63 x 57 mm	TT/SFA

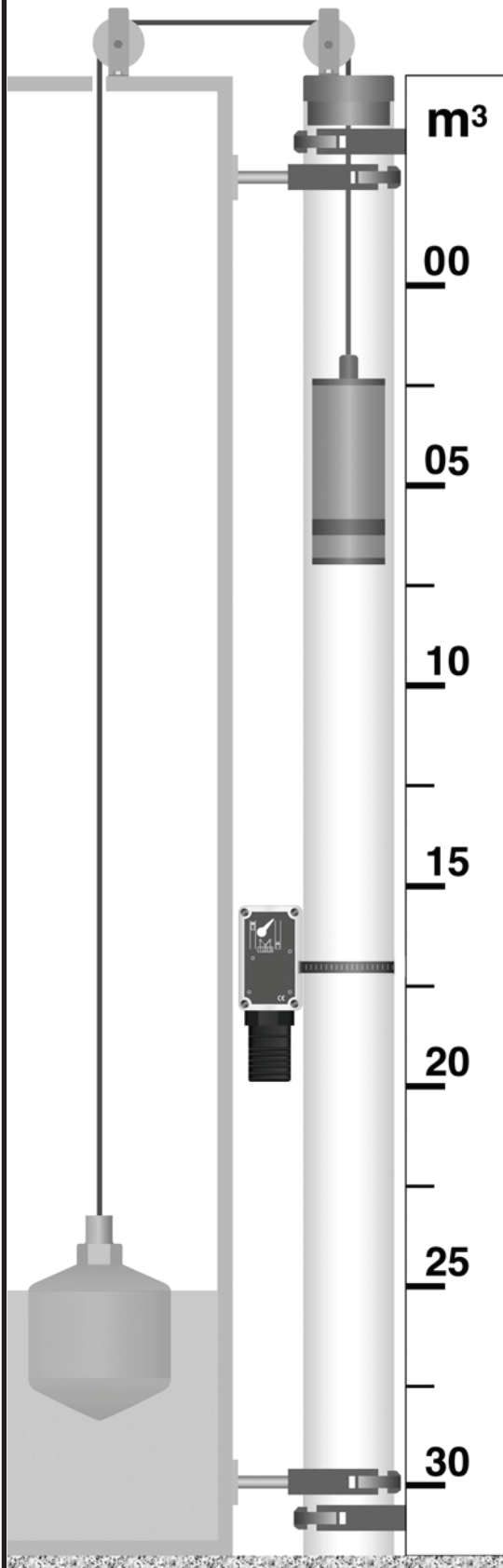

BAMO MESURES

22, Rue de la Voie des Bans - Z.I. de la Gare - 95100 ARGENTEUIL
Tél : (+33) 01 30 25 83 20 - Web : www.bamo.fr
Fax : (+33) 01 34 10 16 05 - E-mail : info@bamo.fr

**CABLE OPERATED
LEVEL INDICATOR
SFA**

NIV

583-01/1