

INTRINSIC SAFETY SEPARATING RELAY, 2 CHANNELS

for contact or proximity detector, or
logic signal

TMT2-SI

The TMT2-SI has **intrinsic safety inputs** :

this is **associated equipment**, placed in safe area.

It has input circuits for connection to a sensor placed in hazardous area and output circuits for connection in safe area only.

This instrument has obtained a CE examination certificate of the type according to the prescriptions of the standards EN 60079-0 (2006), EN 60079-11 (2007), EN 60079-26 (2007), EN 61241-0 (2006) et EN 61241-11 (2006) in accordance with the directive ATEX 94/9/CE.

marking: **CE 0344**  **II(1)GD, [Ex ia] IIC and [Ex iaD]**

The TMT2-SI is an **intrinsic safety separating relay for 2 inputs** :

type "contact" or "proximity detector", or "logic signal" (version "TMT2L"). The 2 outputs are insulated between themselves and of the type "relay" (option "R"), or "transistor" (option "T"), or "TTL logic signal" (option "L").



Functions

- **If input type "proximity detector"**:

on each of the 2 channels jumpers allow activating or de-activating a watching of short-circuits or cable rupture. In the case where an error is detected on an input, the corresponding output will normally be "blocked" (relay still, or transistor insulating, or logic level 0, according to versions).

If the jumper "I207" is in position "AL_V2" the error state of input 1 is reported on output 2 ("blocked" if jumper "I204" is in position "I", otherwise the contrary); in this case input 2 can not be used.

- Programming of the switching state of each channel by jumper.
- Visualisation on front face for each of the 2 channels of the switching state and the presence of an error.

Applications

- PLC input interface.
- Data centralising on PLC.
- Acquisition, regulation, recording, watching of signals.
- Retransmission of logic inputs on panel and switchbox

Environment

- Reduced case dimensions.
- Plug-off connectors for screwed connectings
- Operating temperature : -10°C to +50°C
- Storage temperature : -30°C to +80°C
- CE marking (89/336 rev. 92/31)
- Conform with standards IEC61000-6-4 on rejections and IEC61000-6-2 on immunity (in industrial environment), IEC61000-4-3 level 3, IEC61000-4-4 level 4, IEC61000-4-6 level 3.

Description

- ♦ **Housing** : (H x L x D) 75 x 22.5 x 120 mm (H=108, with terminals)

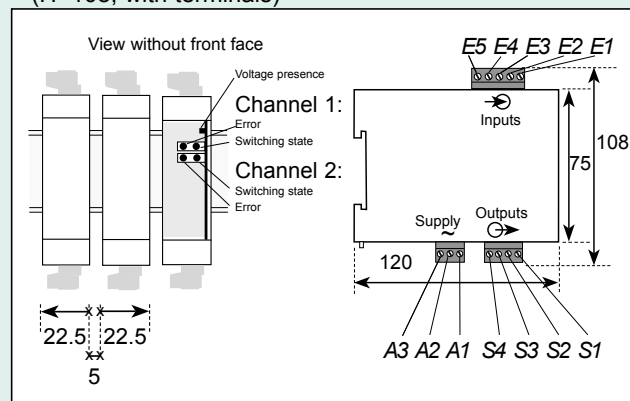

- ♦ **Protection** : Housing / terminals : IP 20

- ♦ **Housing** : Self-extinguishing case of black UL 94VO ABS, for latching on symmetrical DIN rail (mount the cases vertically and provide a 5 mm spacing between each). Plug-off connectors for screwed connectings (2.5mm², flexible or rigid).

- ♦ **Weight** : 205g (with packaging).

Technical features at 23°C

INPUTS (2 channels)

- Potential free contact or proximity detector according to DIN 19234 (NAMUR)
 - Sensor supply voltage..... 8.5V
 - Drawn current if type "contact"..... 8.5 mA
 - Switching setpoint 1.55 mA
 - Hysteresis..... 0.2 mA
 - Impedance..... 1kΩ
 - "sensor rupture" detection setpoint ≤ 0.1 mA
 - "short-circuit" detection setpoint..... ≥ 6 mA

Logic signal

- Max. voltage between E1/E2, E3/E4 10 V
- Switching setpoint 1.55V
- Hysteresis..... 0.2 V
- Impedance..... 100kΩ

OUTPUTS

- Electromagnetic relay**
 - 1 potential free "NO / NC" contact per channel
 - Switching voltage ≤ 250 VAC or 30 VDC
 - Switching current ≤ 5 A (on resistive load)
 - Switching frequency..... ≤ 10 Hz
 - Contact material..... AgCdO
- Transistor**
 - Potential free
 - protection from short-circuits and inversions of polarity.
 - Switching voltage..... ≤ 30 VDC
 - Switching current per channel ≤ 25 mA
 - Voltage waste..... ≤ 1.5V
 - Switching frequency..... ≤ 3 kHz (on load < 5kΩ)

"TTL" logic

- Protection from short-circuits (limitation at 25 mA)
- Low logic level ≤ 0.5V
- Switching frequency.... ≤ 3 kHz

Galvanic partition :

- inputs / [outputs, supply].....3.8kV eff. 50Hz 1min.
- outputs / supply.....2kV eff. 50Hz 1min.
- between "relay" type outputs.....2.5kV eff. 50Hz 1min.
- between "transistor" or "logic" type outputs.. 1.5kV eff. 50Hz 1min.

Power supply : High or low voltage (specify)

- (2) high voltage : 90...265 VAC or 88...350 VDC
- (3) low voltage : 20...40 VAC or 20...64 VDC

Power draw :
on load < 5 VA (3W), empty < 3.5 VA (1.5W)

ELECTRICAL PARAMETERS RELATED TO THE INTRINSIC SAFETY

Inputs	Terminals	U ₀ Vdc	I ₀ (mAdc)	P ₀ (mW)	L ₀ (H)	C ₀ (μF)
Contact or proximity detector	E2, E1 (chan. 1) E4, E3 (chan. 2)	9.6	9.9	24	>1	3.6
Logic signal	E2, E1 (chan. 1) E4, E3 (chan. 2)	9.6	0.097	0.23	>1	3.6

Um < 375 Vdc and Um < 265 Vac

Coding

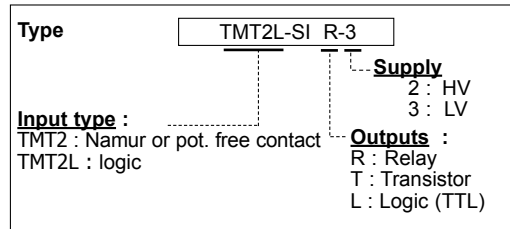

Order example :
For a **2-channel separating relay** with logic input, transistor output, powered in low voltage, request reference : **TMT2L-SI T-3**

Connectings

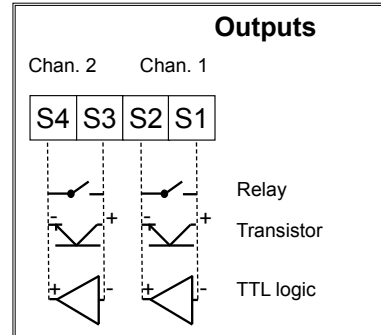
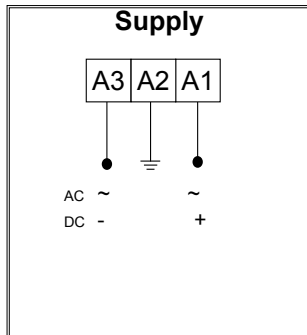
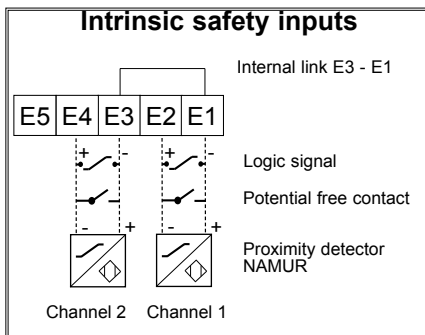

This appliance is dedicated to industrial applications. It has to be installed in an electrical switchbox, or equivalent.



RCS Lyon 444-429-476 - Printed in France.

e-mail : info@ardetem.com
http : //www.ardetem.com

Route de Brindas
Parc d'activité d'Arbora N°2
69510 SOUCIEU EN JARREST
FRANCE

Tél. : 33 (0)4 72 31 31 30
Fax. : 33 (0)4 72 31 31 31

Your representative