

# IMMERSION PROBE FOR TURBIDITY CONTROL CP1

- ON/OFF turbidity control
- PVC probe, IP68
- Optical measurement in Infra Red wavelengths
- Detection: from 50 to 1500 FTU  
or from 600 to 4000 FTU
- Immersion distance of 10 m as a maximum
- Fitting and configuration easy with our TRUBOMAT GS3 controller

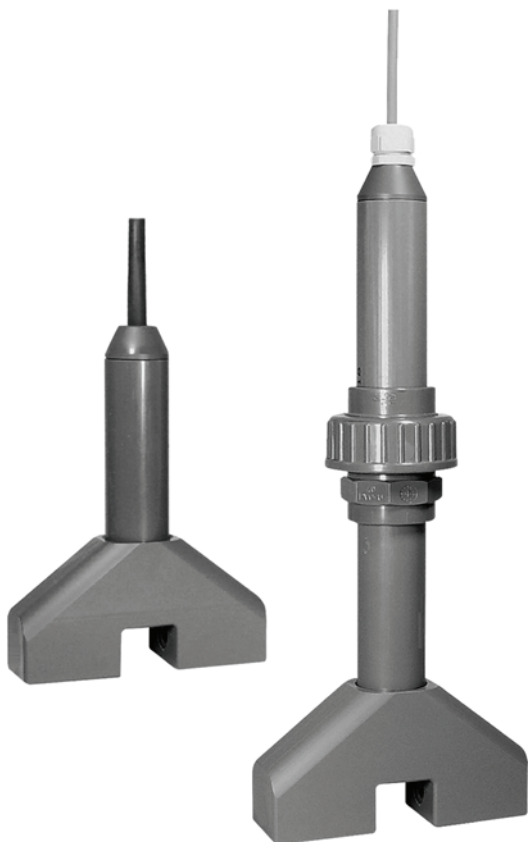

## PRINCIPLE

A complete system includes a CP1 probe (ZO or ZR type) connected to a TRUBOMAT GS3 controller. It provides a contact signal as soon as the turbidity reaches the preset value.

The emitter TT-GS send the IR beam (940 nm pulsed 8 kHz) through the fluid to the receiver TR-GS. The variations due to the turbidity are fully used by the TRUBOMAT to detect the over passing preset value.

To avoid false alarms due to air bubbles or accidental excess of turbidity, switching delays are adjustable from 0 to 10 seconds (increasing and decreasing turbidity).

## APPLICATIONS

- Level detection of blanket sludge
- phase separation detection
- Effluent survey
- Survey on turbidity limits

The complete system offers a low cost detection on blanket sludge in any WWTP.

## OPERATING RANGE

50 to 1500 FTU  
600 to 4000 FTU

## TECHNICAL FEATURES

Material:	PVC
Protection:	IP68
Range:	50...1500 FTU 600...4000 FTU
Immersion depth:	Maximum 10 m
Fluid temperature:	0°C...+60°C
Cable:	Shielded cable 3 x 0.5 mm <sup>2</sup> - Acid and base resistant Length of 6 m as a standard (other length on request)
Mounting:	- Suspended - With PVC stem, 1 or 1.5 m long (other length on request), Maximum 2 m long - With bracket

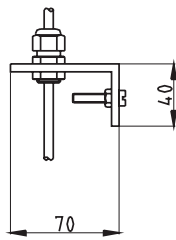

Bracket for CP1 ZK  
with cable gland Pg 9

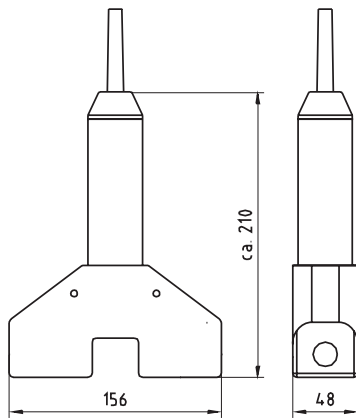

Probe CP1 ZO

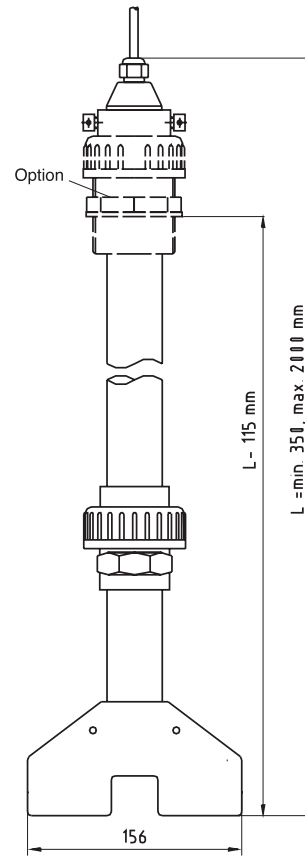

Probe CP1 with stem

## CODE NUMBERS AND REFERENCES

Code	Reference	Designation
425 010	CP1 L Z0	CP1, 50...1500 FTU, Cable 6 m long,
425 020	CP1 L ZK	CP1, 50...1500 FTU, Cable 6 m long, with bracket and cable gland
425 030	CP1 L ZR10	CP1, 50...1500 FTU, Cable 6 m long, with stem 1 m long
425 040	CP1 L ZR15	CP1, 50...1500 FTU, Cable 6 m long, with stem 1.5 m long
425 050	CP1 H Z0	CP1, 600...4000 FTU, Cable 6 m long,
425 060	CP1 H ZK	CP1, 600...4000 FTU, Cable 6 m long with bracket and cable gland
425 070	CP1 HZR10	CP1, 600...4000 FTU, Cable 6 m long, with stem 1 m long
425 080	CP1 H ZR15	CP1, 600...4000 FTU, Cable 6 m long, with stem 1.5 m long

# BAMO MESURES

22, Rue de la Voie des Bans - Z.I. de la Gare - 95100 ARGENTEUIL

Tél : (+33) 01 30 25 83 20 - Web : [www.bamo.fr](http://www.bamo.fr)

Fax : (+33) 01 34 10 16 05 - E-mail : [info@bamo.fr](mailto:info@bamo.fr)

IMMERSION PROBE FOR  
TURBIDITY CONTROL

CP1

TUR

425-01/2

04-04-2008

425 11 01 D