

PROGRAMMABLE CONVERTERS series TPI 401

TPI401 1 output

TPI451 2 insulated analog outputs



Features

- **Universal power supply:**
20 to 270 Vac and 20 to 300 Vdc
- **Process input: (TPI 400/450)**
±100mV, ±1V, ±10V, ±300V, ±20mA
- **Universal input: (TPI 401/451)**
±100mV, ±1V, ±10V, ±300V, ±20mA,
Pt100 3 wire, Ni 100, thermocouple,
resistance and potentiometer.
Average response time: 150ms
- **Supply for 2-wire sensor**
- **Insulated analog outputs (A)**
0-4-20mA current (active/passive)
or 0-10V voltage.

Relay outputs (R) : 2 inverting relays
(8A/250 VAC on resistive load).

Digital data link (N) insulated RS485
Modbus/Jbus

Detection of the sensor rupture.

Insulation between input/outputs/supply.

Self-zero and self-diagnosis.

*Mode driver: the analog output is
piloted by the digital data link, or
locally by the micro-console.*

Function simulation of the input measure.

*Programming either with the micro-console
or by PC via the software SUPERVISION.*

Configuration

Easy programming on front face from a keyboard, with a micro-console or by the PC software SUPERVISION.

Programming with the micro-console

The series TPI accepts 2 types of μ consoles :

- The old generation with 4 electroluminescent alphanumerical green digits
- The new generation with graphical rear-lit LCD

The LCD allows visualising 4 pieces of information:

- the value of the measure,
- the unit of the displayed value,
- the value of the analog output or the marking name of the product,
- the status of the relay outputs and the RS485 data link.

This μ console with LCD also allows the display of this information either vertically or horizontally, according to the sense in which the converter is mounted.

Programming by PC : SUPERVISION

Programming software (Windows environment) allows:

- the storage of configurations as files which can be consulted, modified, duplicated or loaded into the converters,
- the edition and printing of files with or without having a converter connected.

Protection: case / terminals: IP20

Plug-off connectors for screwed connectings
(2.5mm², flexible or rigid)

Weight: 240g (with packaging)

Self-extinguishing case of black UL 94VO ABS.

Mounting in switchbox: latching on symmetrical DIN rail.

Rack version: consult.

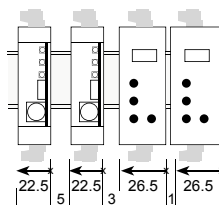

Dimensions: 22.5x75x120 mm
with μ console: 26.5x80x130 mm

Operating T°: -10° to 50°C
Storage T°: -20 to 70°C

♦ **CE** according to IEC 61000-6-4, IEC 61000-6-2 (industrial environment).

♦ Disturbance immunity according to the standard
IEC 61000-6-2 (IEC 61000-4-3 level 3, IEC 61000-4-4 level 4,
IEC 61000-4-6 level 3)

Coding

Type	TPI 4x1 ARN
Outputs:	
A	I/U insulated analog
R	2 inverting relays
N	digital RS 485

Power supply: 20 to 270 Vac and 20 to 300Vdc

Power draw : 3.5 W max. 6 VA max.
Dielectric withstanding : 2 kV-50Hz-1min.

Order example: For a converter with universal input + 1 analog output
+ 2 relays, powered in 230 V, request reference **TPI 401 AR**

Available versions:

TPI 401	A	AR	ARN	-
TPI 451	-	R	-	N

(consult for different configurations)

Dimensions

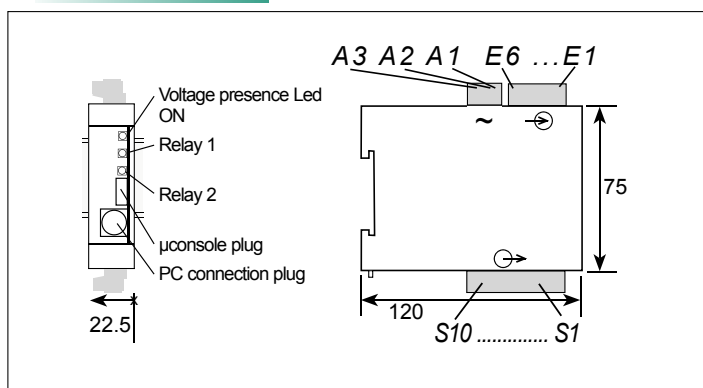

Features

Inputs

TPI 400/450	TPI 401/451	Types of INPUTS	Measure range adjustable from:	Permanent overload	Intrinsic error	Console resolution	Input impedance	
•	•	mA	-22 to +22mA	±100mA	< ±0.05% of the MR	10 µA	Max. drop 0.9V	
•	•	mV	-110 to +110mV	±1V		10 µV		
			-1.1 to +1.1V	±50V		1 mV		
•	•	V	-11 to +11V	±500V		1 mV	≥ 1MΩ	
			-330 to +330V	±600V	10mV			
		Thermocouples Standard IEC 581 J K B R S T E N L W W3 WRE5	°C °F		*(2) <±0.1% of the MR	0.1°C / 0.1°F	≥ 1 MΩ	
	•	Sensor Pt100Ω (1) 3 wire, Standard IEC 751 (DIN 43760)	°C °F		<±0.1% of the MR	0.1°C / 0.1°F	Current 250µA	
	•	Sensor Ni 100 3 wire(1)						
	•	Resistive sensors	Calibers 0-440 Ω and 0-2.2 kΩ (0-8.8 kΩ optional)		<±0.1% of the MR (0.5% for 0-2KΩ)			
	•	Potentiometer	from 100Ω to 10 kΩ					
•	•	Supply for 2-wire sensor	24 Vdc ±15% with protection from short-circuits. 25 mA max.					
•	•	Special linearisation programming up to 20 points	On input: mV, V, mA. Resistive sensors and potentiometer					

- (1) Line resistance <25Ω
 (2) Or 30 µV typical (60µV Max.)
 • CJC efficiency: ±0.03°C/°C ±0.5°C from -5°C to +55°C
 MR measure range

- ▲ A 12 µA pulsed current allows the detection of line or sensor rupture.
 ▲ Cut off : the display of the console and the output of the TPI remain at down scale for an input signal < than the cut off value, programmable from 0% to 100% of the input scale.
 Thermic drift <150ppm /°C

Outputs

TPI 401	TPI 451	Code	Types of OUTPUTS	Features
•	•	A	1 analog Active/pass. current Voltage	Current: direct or reversed 0-20mA Load impedance ≤ Lr 600Ω Voltage: direct or reversed 0-10V Load impedance ≥ Lr 5kΩ(TPI 400/401 TPI 450/451 N) Lr 500kΩ(TPI 450/451 TPI 450/451 R)
•	• (4)	R	2 inverting relays	2 setpoints per relay, configurable on the whole MR. Hysteresis programmable from 0 to 100%. Time delay programmable from 0 to 25 sec. (8A/250VAC on resistive load)
• (5)	• (4)	N	Digital data link RS485 Protocole MODBUS/JBUS insulated. (with or without parity, even or odd; 1 or 2 stop bits)	

- (4) The relay outputs R and the digital data link N are not available simultaneously.
 (5) The digital data link N and the voltage output A are not available simultaneously.

Response time of the outputs:

(for a variation from 0 to 90% of the input signal)
 Average response time: 150 ms (1)
 (1) Add 40 ms for the response time on the analog output.

Galvanic partition: 2kV-50Hz-1min. between supply, input, analog output, relay outputs and digital data link 1kV-50Hz-1min. between analog and digital output, or between 2 analog outputs.

Wiring

Upper connectors

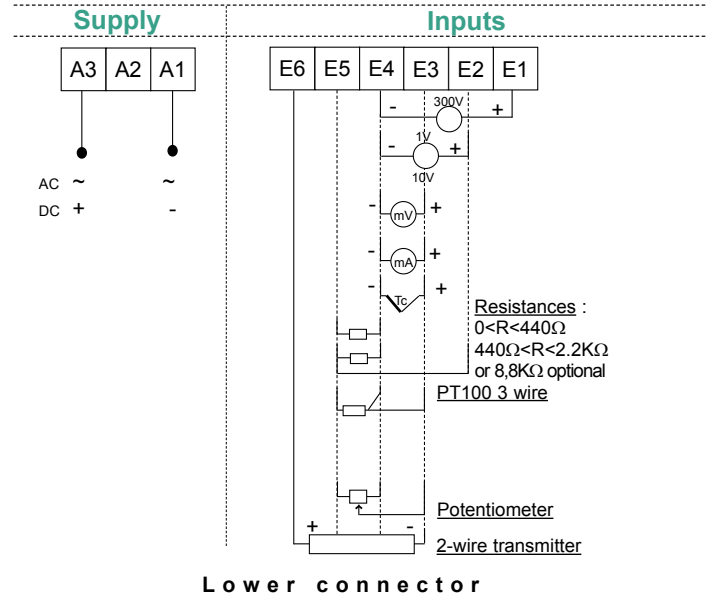

Lower connector

Outputs of the TPI 401 400

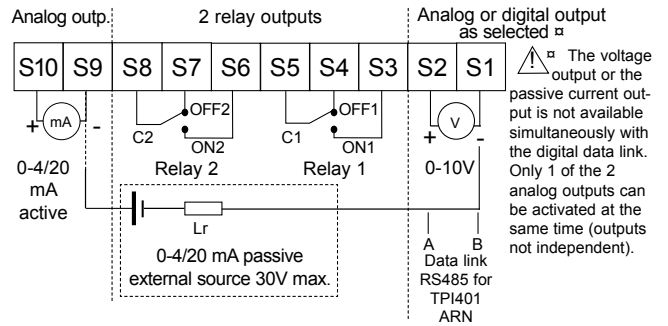

Outputs of the TPI 451 / 450 (R)

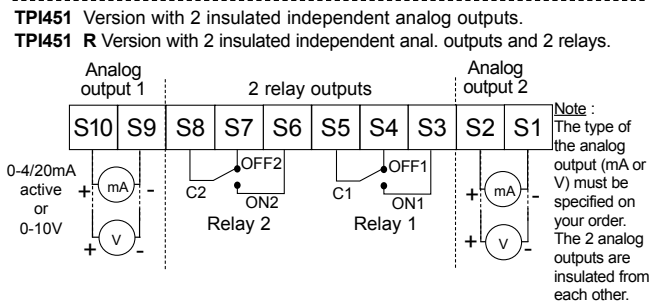

Outputs of the TPI 451 / 450 N

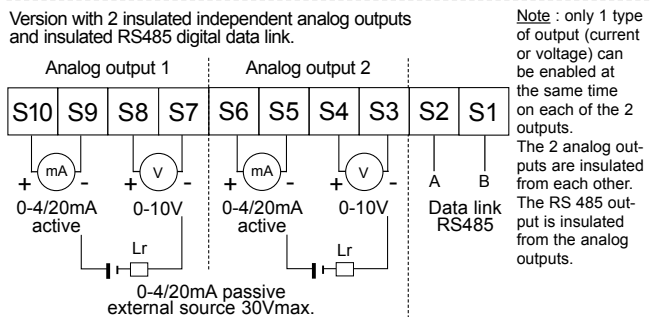

your representative



Route de Brindas
 Parc d'activité d'Arbora N°2
 69510 SOUCIEU EN JARREST
 - FRANCE -

e-mail : info@ardetem.com
 http : //www.ardetem.com

Tél. : 33 (0)4 72 31 31 30
 Fax. : 33 (0)4 72 31 31 31