

# In line turbidity transmitter TURBICUBE

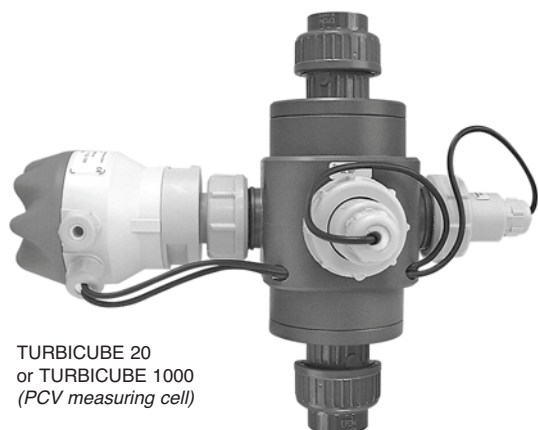

TURBICUBE 20  
or TURBICUBE 1000  
(PCV measuring cell)

**TURBICUBE-20**  
from 0.01 to 20 FNU  
  
or  
**TURBICUBE-1000**  
from 0.1 to 1000 FNU

- Flow-through in-line turbidimeter acc. ISO 7027
- Turbidity transmitter
- With two IR emitters and one IR receiver
- Two models:     0.01...20 FNU (5 ranges)  
                          0.1...1000 FNU (5 ranges)
- 4...20mA output signal (4 wires)
- Flange or thread connection

## PRINCIPLE

The TURBICUBE measures the turbidity of liquids using the light absorption and scattered light measuring method.

The inline measuring cell includes two IR emitters and one IR receiver in pulsating light mode (IR measuring method according ISO 7027).

When interconnected, the BAMOPHOX TUR, measuring amplifier, analyses the 4 to 20 mA signal generated by the TURBICUBE.

## DESCRIPTION

The flow-through cell allows the turbidity measurement directly on the line, without sampling system. Its built-in transmitter is convenient for transmitting the signal to installed DCS or PLC or BAMOPHOX TUR. The 4-20 mA corresponds to the DIP Switch selectable range:

TURBICUBE 20:           from 0.01 to 20 FNU in 5 selectable ranges  
TURBICUBE 1000:       from 0.1 to 1000 FNU in 5 selectable ranges

## APPLICATIONS

- Drinkable and waste water plants, well water monitoring
- Filtration control, flocculants dosage, phase separation
- Pollution survey

## EXAMPLE

Distilled water:	0 FNU
Filtered apple juice:	2...4 FNU
River water:	1...4 FNU
Milk (fat 3%):	around 4000 FNU
Filtered Pale ale:	1...6 FNU
Raw beer:	20...400 FNU
Distilled water, 10% milk:	around 20 FNU



TURBICUBE 20  
or TURBICUBE 1000  
(PPH measuring cell)

# BAMO MESURES

22, Rue de la Voie des Bans - Z.I. de la Gare - 95100 ARGENTEUIL

Tél : (+33) 01 30 25 83 20 - Web : [www.bamo.fr](http://www.bamo.fr)

Fax : (+33) 01 34 10 16 05 - E-mail : [info@bamo.fr](mailto:info@bamo.fr)

In line turbidity transmitter  
**TURBICUBE**

04-09-2007

444 I1 01 B

**TUR**

**444-01/1**

## TECHNICAL FEATURES

Terminal housing:	PBT, IP65
Auxiliary power supply:	24V DC (10...30 V DC); connected load 0.5 W. Note: connecting also the measuring circuit to the auxiliary power supply of the load, it increases of 24 V DC x 20mA = 0,48W
Power consumption:	0,6 W
Output signal:	4-20 mA for connection to the BAMOPHOX TUR 436. Note: if a different measuring amplifier is used, an external 10 to 30 V DC voltage source is required.
Ambient temperature:	+ 5...+ 45°C
Process temperature:	+ 5...+ 60°C
Accuracy:	± 5% reading, ± 1% full scale in use
Maximum pressure:	6 bar at 20°C / 1 bar at 60°C
Status indication:	correct is a green LED; failure is a red LED
Selectable ranges TURBICUBE 1000 :	from 0,1 to 50 / ...100 / ...200 / ...500 (300*) FNU from 100 to 1000 FNU * fixtures with DN80/DN100
Selectable ranges TURBICUBE 20:	from 0,01 to 1 / ...2 / ...5 / ...10 / ...20 FNU
Wetted parts:	Plane wall measuring cell from polymers (PCV or PP) and anti-fouling ETR-glasses.
Sealing: EPDM (FPM as an option)	
Process connections:	from DN 20 to DN 100, flanges or union socket ends
<b>CE Mark:</b>	In accordance with low-voltage directive (73/23/EWG), EMC directives (89/336/EEC)

## DIMENSIONS

DN	(d)	PVC model		pH model	
		L (-0/+2 mm) (Union socket ends)	L (±2 mm) (Flanges acc. DIN 2501)	L (-0/+2 mm) (Union socket ends)	L (±2 mm) (Flanges acc. DIN 2501)
DN 20	Ø 25	240	240	300	300
DN 25	Ø 32	240	240	300	300
DN 32	Ø 40	240	240	300	300
DN 40	Ø 50	240	240	300	300
DN 50	Ø 63	262	262	342	300
DN 65	Ø 75	314	314	342	300
DN 80	Ø 90	347	347	394	400
DN 100	Ø 110	347	347	394	400

**Installation:** Only for vertical ascending tubes!

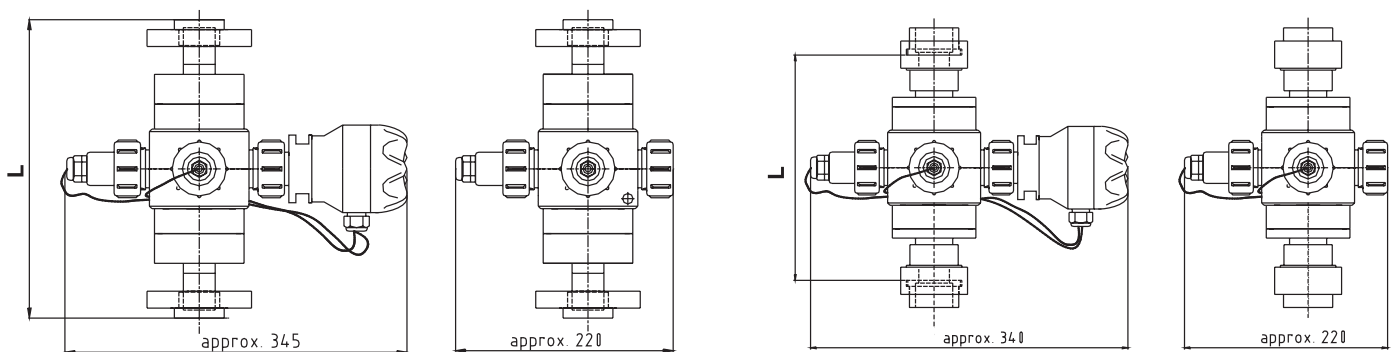

**Example: Turbicube FF ..2**  
pH model with flanges acc. ISO 7005,  
EN 1092, DIN 2501

**Example: Turbicube VV ..2**  
PVC model with union socket ends

# BAMO MESURES

22, Rue de la Voie des Bans - Z.I. de la Gare - 95100 ARGENTEUIL  
Tél : (+33) 01 30 25 83 20 - Web : [www.bamo.fr](http://www.bamo.fr)  
Fax : (+33) 01 34 10 16 05 - E-mail : [info@bamo.fr](mailto:info@bamo.fr)

In line turbidity transmitter  
**TURBICUBE**

04-09-2007

444 I1 01 B

**TUR**

**444-01/2**

Code	Reference	Description	
444 112	TURB. - VV - 1000 - 1 - 2 - M	Sensor set PCV – Range 0,1...1000 FNU – Union PCV sockets ends	DN 20
444 113	TURB. - VV - 1000 - 1 - 3 - M	-	DN 25
444 114	TURB. - VV - 1000 - 1 - 4 - M	-	DN 32
444 115	TURB. - VV - 1000 - 1 - 5 - M	-	DN 40
444 116	TURB. - VV - 1000 - 1 - 6 - M	-	DN 50
444 117	TURB. - VV - 1000 - 1 - 7 - M	-	DN 65
444 118	TURB. - VV - 1000 - 1 - 8 - M	-	DN 80
444 119	TURB. - VV - 1000 - 1 - 9 - M	-	DN 100
444 212	TURB. - VV - 20 - 1 - 2 - M	Sensor set PCV – Range 0,01...20 FNU – Union PCV sockets ends	DN 20
444 213	TURB. - VV - 20 - 1 - 3 - M	-	DN 25
444 214	TURB. - VV - 20 - 1 - 4 - M	-	DN 32
444 215	TURB. - VV - 20 - 1 - 5 - M	-	DN 40
444 216	TURB. - VV - 20 - 1 - 6 - M	-	DN 50
444 217	TURB. - VV - 20 - 1 - 7 - M	-	DN 65
444 218	TURB. - VV - 20 - 1 - 8 - M	-	DN 80
444 219	TURB. - VV - 20 - 1 - 9 - M	-	DN 100
444 122	TURB. - FF - 1000 - 1 - 2 - M	Sensor set PCV – Range 0,1...1000 FNU – with flanges	DN 20
444 123	TURB. - FF - 1000 - 1 - 3 - M	-	DN 25
444 124	TURB. - FF - 1000 - 1 - 4 - M	-	DN 32
444 125	TURB. - FF - 1000 - 1 - 5 - M	-	DN 40
444 126	TURB. - FF - 1000 - 1 - 6 - M	-	DN 50
444 127	TURB. - FF - 1000 - 1 - 7 - M	-	DN 65
444 128	TURB. - FF - 1000 - 1 - 8 - M	-	DN 80
444 129	TURB. - FF - 1000 - 1 - 9 - M	-	DN 100
444 222	TURB. - FF - 20 - 1 - 2 - M	Sensor set PCV – Range 0,01...20 FNU – with flanges	DN 20
444 223	TURB. - FF - 20 - 1 - 3 - M	-	DN 25
444 224	TURB. - FF - 20 - 1 - 4 - M	-	DN 32
444 225	TURB. - FF - 20 - 1 - 5 - M	-	DN 40
444 226	TURB. - FF - 20 - 1 - 6 - M	-	DN 50
444 227	TURB. - FF - 20 - 1 - 7 - M	-	DN 65
444 228	TURB. - FF - 20 - 1 - 8 - M	-	DN 80
444 229	TURB. - FF - 20 - 1 - 9 - M	-	DN 100
444 322	TURB. - VV - 1000 - 2 - 2 - M	Sensor set PPH – Range 0,1...1000 FNU – Union PPH sockets ends	DN 20
444 323	TURB. - VV - 1000 - 2 - 3 - M	-	DN 25
444 324	TURB. - VV - 1000 - 2 - 4 - M	-	DN 32
444 325	TURB. - VV - 1000 - 2 - 5 - M	-	DN 40
444 326	TURB. - VV - 1000 - 2 - 6 - M	-	DN 50
444 327	TURB. - VV - 1000 - 2 - 7 - M	-	DN 65
444 328	TURB. - VV - 1000 - 2 - 8 - M	-	DN 80
444 329	TURB. - VV - 1000 - 2 - 9 - M	-	DN 100
444 422	TURB. - VV - 20 - 2 - 2 - M	Sensor set PPH – Range 0,01...20 FNU – Union PPH sockets ends	DN 20
444 423	TURB. - VV - 20 - 2 - 3 - M	-	DN 25
444 424	TURB. - VV - 20 - 2 - 4 - M	-	DN 32
444 425	TURB. - VV - 20 - 2 - 5 - M	-	DN 40
444 426	TURB. - VV - 20 - 2 - 6 - M	-	DN 50
444 427	TURB. - VV - 20 - 2 - 7 - M	-	DN 65
444 428	TURB. - VV - 20 - 2 - 8 - M	-	DN 80
444 429	TURB. - VV - 20 - 2 - 9 - M	-	DN 100
444 332	TURB. - FF - 1000 - 2 - 2 - M	Sensor set PPH – Range 0,1...1000 FNU – with flanges	DN 20
444 333	TURB. - FF - 1000 - 2 - 3 - M	-	DN 25
444 334	TURB. - FF - 1000 - 2 - 4 - M	-	DN 32
444 335	TURB. - FF - 1000 - 2 - 5 - M	-	DN 40
444 336	TURB. - FF - 1000 - 2 - 6 - M	-	DN 50
444 337	TURB. - FF - 1000 - 2 - 7 - M	-	DN 65
444 338	TURB. - FF - 1000 - 2 - 8 - M	-	DN 80
444 339	TURB. - FF - 1000 - 2 - 9 - M	-	DN 100
444 433	TURB. - FF - 20 - 2 - 3 - M	Sensor set PPH – Range 0,01...20 FNU – with flanges	DN 20
444 432	TURB. - FF - 20 - 2 - 2 - M	-	DN 25
444 434	TURB. - FF - 20 - 2 - 4 - M	-	DN 32
444 435	TURB. - FF - 20 - 2 - 5 - M	-	DN 40
444 436	TURB. - FF - 20 - 2 - 6 - M	-	DN 50
444 437	TURB. - FF - 20 - 2 - 7 - M	-	DN 65
444 438	TURB. - FF - 20 - 2 - 8 - M	-	DN 80
444 439	TURB. - FF - 20 - 2 - 9 - M	-	DN 100



22, Rue de la Voie des Bans - Z.I. de la Gare - 95100 ARGENTEUIL  
 Tél : (+33) 01 30 25 83 20 - Web : [www.bamo.fr](http://www.bamo.fr)  
 Fax : (+33) 01 34 10 16 05 - E-mail : [info@bamo.fr](mailto:info@bamo.fr)

01-02-2007

04-09-2007

**In line turbidity transmitter**  
**TURBICUBE**

**TUR**

---

**444-01/3**